

CubeSat: A new Generation of Picosatellite for Education and Industry Low-Cost Space Experimentation

Mr. Hank Heidt¹, Prof. Jordi Puig-Suari², Prof. Augustus S. Moore³, Prof. Shinichi Nakasuka⁴,
Prof. Robert J. Twiggs⁵

¹NetDecide Corporation, tel: 703-610-523, e-mail: hheidt@erols.com

²California Polytechnic State University, tel: 805-756-6479, e-mail: jpuigsua@calpoly.edu

³Dartmouth College, e-mail: Augustus.S.Moore@Dartmouth.EDU

⁴University of Tokyo, tel: (033) 812-2111 EX. 6590, e-mail: nakasuka@space.t.u-tokyo.ac.jp

⁵Stanford University, tel: 650-723-8651, e-mail: btwiggs@leland.stanford.edu

ABSTRACT

The launch and deployment of picosatellites from the Stanford University OPAL microsatellite in February 2000 demonstrate the feasibility and practicability of a new age of space experimentation. Two of the six picosatellites deployed from OPAL were built by The Aerospace Corporation in El Segundo, CA and demonstrated new space testing of MEMS RF switches and intersatellite and ground communication with low power wireless radios. These picosatellites weighting less than one kilogram with dimensions of 4x3x1 inch were built as test platforms for DARPA and were constructed and delivered for flight in less than nine months.

From this experience, a new generation of picosats called CubeSat is being developed by a number of organizations and universities to accelerate opportunities with small, low construction cost, low launch cost space experiment platforms. California Polytechnic State University at San Luis Obispo, CA is developing launcher tubes that can be part of a satellite or attached to any orbiting platform to launch from 1-3 CubeSats per tube. These tubes will contain CubeSats of 1-2 kilograms weight and approximately 4-inch cube shape. This size as compared to the picosatellites launched on OPAL provide better surfaces for practical solar power generation, physical size for components and a shape that provides better space thermal stability.

A consortium of potential CubeSat developers is now wide ranging with universities from Japan, New Zealand, the US, amateur radio clubs and industry participants. Potential launch opportunities exist with the Russian Dnepr (SS-18) about twice/year, with the OSP (Minotaur) every 18 months and possible 100

km altitude orbits from the second stage of Delta launches.

This paper will review the OPAL picosatellite launch and performance, the launcher being built for the CubeSat, the development and payloads of CubeSat developers and cost and timing of launch opportunities.

TABLE OF CONTENTS

1. Introduction
2. Stanford University OPAL Program
3. CubeSat Development Program
4. Participants in CubeSat Program
5. Launch Opportunities
6. Conclusions
7. Acknowledgements
8. References

1. INTRODUCTION

The current trend in satellites to do more for less cost has led to the "Smaller, Cheaper, Faster, Better" space missions. It is generally resulting in many cases of doing things the same way as before in a somewhat smaller format for less cost, but this has been cited as the basis for some of NASA's recent deep space mission failures.

To support some science missions and in proposing new missions, the trend is now to see what can be done by decreasing the spacecraft sizes by orders of magnitude. This is becoming more practical with the rapid advances in decreasing electronics size, in greatly increased capability and very low power consumption. This decrease in size also

directly benefits the mission cost in lower launch costs.

There are several programs now exploring micro, nano and pico satellite sizes. These sizes ranging from <100kg to <1kg are being developed and tested by combined programs such as the ones discussed in this paper with Stanford University, The Aerospace Corporation, Santa Clara University, University of Tokyo, Dartmouth College, California Polytechnic State University and groups of private amateur satellite enthusiasts.

This paper will describe the experience of Stanford University with a student built microsatellites and their experience in providing launch opportunities for six small picosatellites in January 2000. It will also describe a follow-on program for a picosatellite called CubeSat as a collaborative effort to continue developing the picosatellite, provide a convenient low cost launch interface and coordinate launch activities.

2. STANFORD UNIVERSITY OPAL PROGRAM

2.1 Introduction

The Space Systems Development Laboratory at the Department of Aeronautics and Astronautics at Stanford University was established in 1994 with the purpose of providing project based learning programs for engineering graduate and undergraduate students to gain experience in systems engineering. To accomplish this goal, the program was designed to take students through the life cycle of a project, in this case the design, development, fabrication, testing, launch integration and space operations of a microsatellite. Additional goals for the laboratory were to build the facilities, curriculum and research infrastructure for future laboratory programs.

2.2 Microsatellite Development program plan

The program plan¹⁻² at the Space Systems Development Laboratory (SSDL) was to have programs with the following attributes:

- Program team student managed
- Student designed
- Design assisted by mentor group and support of industry specialists
- Complete from design to “ready for launch” in one year
- Out of pocket cost not to exceed \$50,000
- Use of commercial off-the-shelf components
- Spacecraft operational life of one year

The students were responsible for the selection of the program manager, systems engineer, subsystem managers and other tasks. This was to be like a development team within industry. Students were given general design parameters for the satellite such as size, weight, expected launch orbits, some possible experiments to be flown, communication frequency bands and an approximate budget for each of the subsystems. The mentors and industry experts would provide design counseling, but could not do the designs or fabricate components for students.

The students could select experiments that they wanted to fly, but outside paying experiments were solicited to help cover the materials and parts costs of the program as well as for laboratory development and student travel. These outside experiments would provide the students with experience for dealing with an outside customer and valuable interaction with industry and government customers.

It was expected that if a microsatellite could be completed in nearly one year, that a new satellite design would be initiated each year with each new group of students entering the graduate program³⁻⁴.

2.3 The First Satellite SAPPHIRE

The first student built satellite, SAPPHIRE, was started at Stanford in April 1994. This project was started without any opportunity to launch, but on the faith that a free or low cost launch would become available when the satellite was completed.

The initial concepts for SAPPHIRE⁵ are shown in Figures 2.1 and 2.2. A stacked modular approach was selected with hexagonal shape. The initial parameters were for a 20kg weight, 18 inch diameter and 12 inch high structure.

The structure was a stack of modular shelves made from aluminum honeycomb. There were four longitudinal bolts with spacers that formed the stacked structure. The outer solar panels provided only the surface for mounting the solar cells and external attachments such as antennas and the launch interface.

The final SAPPHIRE contained two student experiments, a B/W Logitech CCD camera, a voice synthesizer and the one government sponsored payload by JPL was as set of MEMS infrared sensors. Thus the name SAPPHIRE (Stanford Audio Phonic Photographic InfRed Experiment) was derived. SAPPHIRE used amateur radios and was built to operate in the amateur frequency J-mode (2m 145MHz uplink and 70cm 437MHz downlink). It used a Motorola 68332 microcontroller for the C&DH, NiCad Batteries and GaAs solar cells. If launched into a polar noon-midnight orbit, the estimated average power would be 78 watts. The passive magnetic stabilization scheme is shown in Figure 2.3 and the finished microsatellite in Figure 2.4.

SAPPHIRE was completed in June of 1998 and at the time of writing the paper is scheduled for launch in late 2002

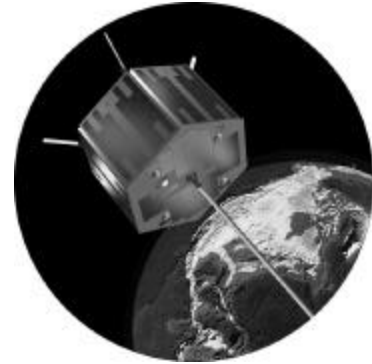

Figure 2.1 SAPPHIRE Concept



Figure 2.2 Stacked Module Concept

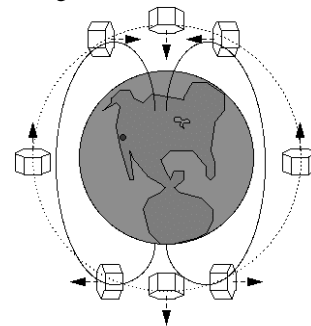

Figure 2.3 Magnetic Passive Stabilization

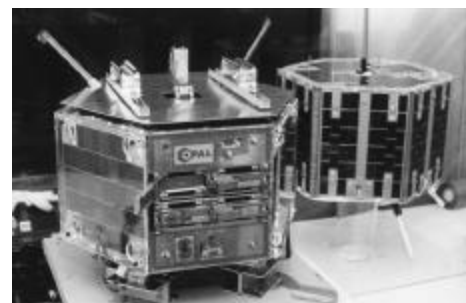

Figure 2.4 OPAL with SAPPHIRE shown in Background

2.4 The Second Satellite OPAL

The second SSDL satellite called OPAL⁶ was started in April 1995. The initial major payload concept for OPAL was to demonstrate Mother-Daughter satellite technology where a mother satellite would carry a number of smaller satellites internally, then when in orbit could be commanded to release these Daughter satellites. By a general size convention, the Stanford SAPPHIRE and OPAL are considered microsattellites (> 10kg, <100kg); the Daughter satellites are considered picosatellites or picosats (>0.1kg, ~<1kg).

An opportunity was found to launch the OPAL in early 1998 with sponsorship from DARPA and in cooperation to launch some Picosatellites for The Aerospace Corporation. This launch was on a new Air Force launch vehicle called the Minotaur (also Orbital-Suborbital Platform - OSP), which used the first two stages of a Minuteman II missile and the last two stages of the Orbital Sciences Corporation Pegasus launch vehicle

The OPAL (Orbiting Automated Picosat Launcher) final design ended up with two of the launcher types shown in Figure 2.5. OPAL carried six picosats, four were 4x3x1 inch and 2 were 8x3x1 inch. The final configuration of the launcher tubes is shown in Figure 2.6 while one picosat is being loaded. The other two experiments were an experimental magnetometer being tested for the Gravity Probe-B project at Stanford University and several sets of commercial accelerometers being tested for JPL.

The launch had delays from September 1999 to January 2000. OPAL was mounted on the multiple payload adapter on the Air Force Minotaur at Vandenberg AFB, CA where final check out is performed in late December 1999. Initial launch was scheduled for September 1999.

OPAL was successfully launched on January 22, 2000 from Vandenberg AFB, CA on the Minotaur. OPAL was initially operated from the SRI large 30-meter antenna on the Stanford. The picosats were released about one week after the launch via radio commands from the ground station. The Aerospace Picosatellites operated for several days on batteries and successfully accomplished their mission objective.

One of the smaller picosats called Stensat was built by a group of amateur radio operators from the Washington D.C. area. It was the only picosat with solar cells and secondary batteries. No long-term response was received from it after launch. Students at Santa Clara University built three other picosats. No response was heard from them either.

OPAL successfully accomplished its mission by launching the picosatellites and testing the secondary experiments. Solar panel current data is shown in Figure 2.7 before an after picosat launch. Initial temperature excursions are shown in Figure 2.8. OPAL continues to operate at the time of this paper.

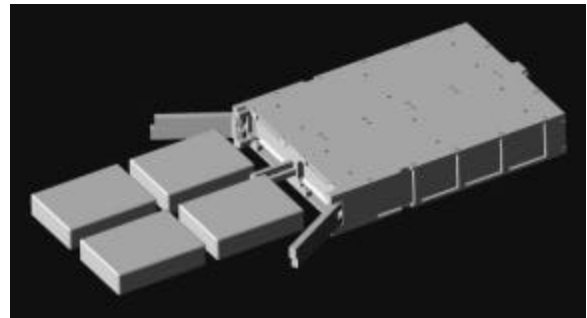

Figure 2.5 OPAL launcher concept



Figure 2.6 Loading a Picosat into OPAL

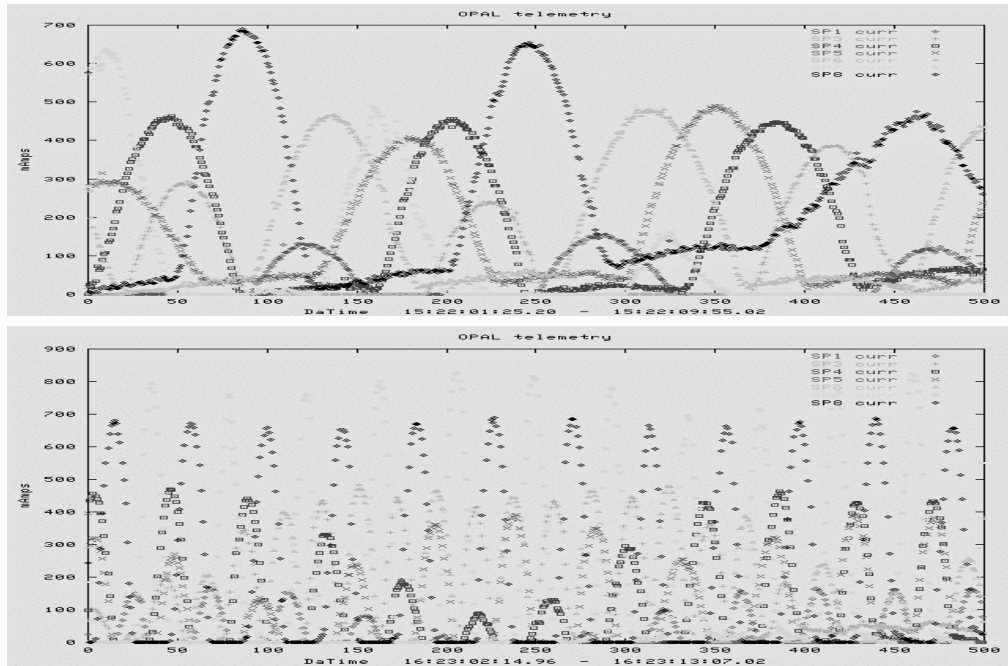

Figure 2.7 OPAL solar panel currents before after picosat launch

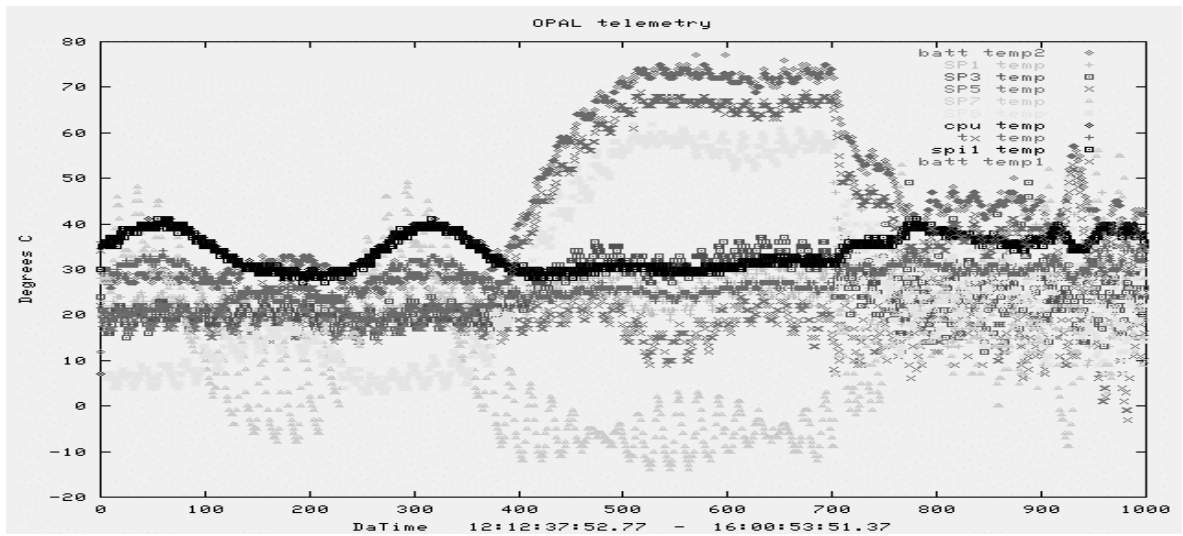

Figure 2.8 OPAL temperatures before and after picosat launch

3. CUBESAT DEVELOPMENT PROGRAM

After the experience gained with OPAL and the launch of the picosatellites, it was determined that picosatellites could be used for many useful space missions as well as a practical space education program.

The nominal OPAL picosatellite was 4x3x1 inch. To get sufficient power from body mounted solar cells, it was determined that a better size would be a cube that had enough surface area to be able to generate at least two watts with the present state-of-the-art solar cells. This was found to be practical with the new 25% efficient triple-junction GaAs cells on a surface of 3.5x3.5 inches.

It was found that the OPAL tube launcher provided practical means of launching picosats since it did not require a direct interface for each picosatellite. The picosatellite was held by four corners with two per launch tube. From this experience, it was decided to design a cube that was 4 inches per side. This allowed room for the solar panels and room to contain the cube on some rails in a launcher tube. With each cube being 4 inches long, it was decided to do an initial design for a launch tube that would hold 3 cubes. Thus the new picosatellite called CubeSat and launcher tube was conceived.

Since the students at Stanford University were all occupied building microsatellites, it was decided to form a collaborative relationship between Stanford and California Polytechnic State University (Cal Poly). Cal Poly also had a reputation as a very hands-on undergraduate engineering university. This collaborative effort was established in the fall of 1999 where Cal Poly would complete the launcher design, build a prototype and evaluate for improvements. The first prototype of this launch and mass model CubeSats is shown in Figure 3.1

The CubeSat program was announced to many of the organizations, educational and amateur groups that were interested in building low cost picosatellites. This paper has descriptions of the launcher from Cal Poly and CubeSat developments from an amateur radio group in Washington D.C. called The Stensat Group, University of Tokyo, and Dartmouth College. There are now approximately 20 organizations world wide that are beginning development of the CubeSat picosatellite.



Figure 3.1 Prototype CubeSat Launcher and Mass CubeSat Models

4. PARTICIPANTS IN CUBESAT PROGRAM

4.1 The Stensat Group

4.1.1 Introduction

The Stensat Team is a group of engineers including amateur radio operators who came together to design a satellite because we are engineers and have nothing better to do. We wanted an unusual hobby and figured this can't be too strange without the risk of being put in a mental institute. Kevin Doherty, Hank Heidt, Jim Bobbus, and Dave Nemai made up the original group for the first Stensat amateur satellite. Joining the CubeSat program is Ivan Galysh and Gil Dutchover from the Naval Research Laboratory. Each member brings a unique skill to the group and has the great desire to design and launch a successful satellite.

We were asked to develop a standardized generic vehicle. The purpose is to design a bus once and allow users to concentrate on the payload and not the spacecraft design. The CubeSat design will provide a standard bus to allow simple and easy control of the

payload while allowing flexibility in the design of the payload.

4.1.2 CubeSat Design

The basic design of the satellite is comprised of a cube structure with a stack of circuit boards inside. Each face of the satellite will be covered with solar cells. The center of the satellite will have two rechargeable batteries. The batteries split the functions of the satellite into two parts. One half of the satellite contains the satellite computer, communications electronics, and attitude control system. The other half is available for a payload.

The CubeSat design is influenced by target characteristics defined by the group and constraints placed by the CubeSat Program. The CubeSat program constraints are the dimensions and mass. The group defines all other design characteristics.

The CubeSat program put a couple of constraints on the design of the satellite. The first constraint was the dimensions to be a ten-centimeter cube. The cube also requires having rub rails for deployment out of the CubeSat launcher. The other requirement is the mass of the satellite. The current constraint is one kilogram. This constraint imposes significant limitations and challenges in designing the structure of the satellite. A 10-centimeter cube of water has a mass of one kilogram. Materials used in the satellite structure have a significantly higher specific density than water. This limitation requires a creative approach to designing the structure. A 10-centimeter cube will have a large empty volume inside. The current CubeSat design has a mass of about 800 grams leaving 200 grams for the payload.

There are several group defined target characteristics influencing the design of the CubeSat. The reproduction of the CubeSat is to be less than one thousand dollars. The design is to be simple and use standard commercial components. The critical components selected should have some radiation data associated with it. For example, Motorola using the MOSAIC process manufactures the transmitter and receiver integrated circuits. This process is known to produce radiation tolerant devices.

Another characteristic includes low power consumption. Available power is to be 1 watt. Bus mean power is specified to be about 250 milliwatts. Redundancy is designed into portions of the power system. Most of the redundancy lies in the solar cell circuitry and power distribution. Each face of the

satellite contains eight solar cells. Four solar cells are connected in series. The two series of solar cells on each face are connected in parallel. If a solar cell fails on a face, only four solar cells are lost. The other four still contribute to the satellite power bus. Each face is connected in parallel. The batteries are also redundant. Circuitry isolates the batteries from each other while allowing them to contribute to the bus power.

To minimize components and structural mass, some components have multiple purposes. The solar cells will provide power and also be used as sun sensors. The printed circuit boards with the solar cells also have a coil pattern on the opposite side for use as the magnetorquer coils. The circuit board stack containing the satellite processor, communications, and payload will also be structural members.

Payload services are designed to provide flexibility in operating the payload. Communications and control from the satellite processor include an IIC bus and digital control signals. The IIC bus was developed by Philips Semiconductor and provides a simple serial interface to the payload. Four digital bidirectional lines are available to the payload. Two analog to digital converter inputs are made available to the payload. A power control signal is provided to allow the satellite processor to power down the payload. A payload reset signal is also provided. The receiver audio signal is provided to the payload. This allows the payload to monitor received signals. The user can communicate directly with the payload through the receiver. The payload also has access to the transmitter modulation signal. When allowed, the payload can generate its own modulation for transmission.

4.1.3 Current Design

The current CubeSat design uses some of the design from the original Stensat picosatellite. The CubeSat will use the same uplink and downlink frequencies and modulations. The receiver uses a Motorola MC13136 single chip receiver. It is designed to receive on the 2-meter amateur radio band. The gain of the receiver is about 100 dBm. It can support FSK modulation bit rates up to 9600 baud. The receiver operates at a voltage range from 3 volts to 5 volts. It consumes a mere 15 milliamperes.

The transmitter uses the Motorola MC13176 single chip transmitter. It operates in the 70-centimeter amateur radio band. It can support up to 9600-baud FSK modulation bit rates. The transmitter operates at

3 volts. It is connected to an RF Microdevices RF2104 single chop amplifier. At 3 volts, it can output up to .5 watts consuming 300 milliamperes.

The integrated circuits used in the receiver and transmitter are radiation tolerant. Based on data and testing from other satellite programs, the Motorola devices are manufactured using the MOSAIC process. This process happens to be very radiation tolerant. The RF Microdevices RF2104 amplifier uses bipolar-junction technology and is also fairly radiation tolerant. These devices have been used in previous commercial and military satellites.

The antennas are deployable antennas mounted on the surface of the satellite. It uses the rub rails in the launcher for deployment. The antennas are constructed on a piece of printed circuit board as a copper trace. There are four such circuit boards, two for the uplink and two for the downlink.

A typical amateur radio satellite ground station can be used to communicate with the CubeSat. All modulation techniques and frequencies are typical.

The power system consists of the solar cells, batteries, and the power distribution and control circuitry. Each face of the satellite contains eight solar cells. The solar cells are grouped into two sets of four solar cells. Each set of solar cells is connected in series. The two sets on each face are connected together in parallel. They are isolated with schotky diodes. If one series fails, the other series can still be used. Each face is connected in parallel. This configuration maximizes redundancy and maximizes power efficiency for the circuitry.

The batteries selected are lithium-ion rechargeable cells. The cells need special handling. They operate normally between 3.1 volts and 4.2 volts. If the cells are discharged too much or overcharged, the cells may explode. The power circuitry contains circuitry to maintain safe operation of the cells. The power converters are charge pump circuits. The power bus is unregulated. The voltage can range from 3 volts to 4 volts.

The satellite controller contains a single chip computer. The processor selected is a PIC controller from Microchip. It is a PIC16C77. The PIC contains an eight channel eight-bit analog to digital converter. It also contains several digital ports. The controller accepts commands from a DTMF decoder using a dual tone sequence. The controller also generates AX.25 telemetry packets that are APRS compatible.

Heidt

An MX614 FSK transceiver is used to generate the AFSK tones. The telemetry packet contains environmental sensor data, payload sensor data, and operation status. The controller monitors its environment with the analog to digital converter. The inputs of the analog to digital converter are connected to a temperature sensor, bus voltage sensor, bus current sensor, and two payload analog signals. The four payload digital signals are connected directly to the controller. Each digital signal can be commanded to operate as an input or an output. The state and direction of each signal is included in the telemetry packet.

The satellite controller board contains a latchup detection circuit. Being in orbit, the processor is exposed to high energy particles. Eventually, the processor will be hit by a high energy particle and have one or more transistors latched in an improper state. This can cause the processor to draw a large amount of current. The latchup detection circuit is designed to detect a sudden increase in current and cycle the power to the processor. Cycling power clears up the latchup. Not all high energy particles cause a latchup. Some will cause a bit flip called a single event upset (SEU). An SEU can cause data to be corrupted or program execution error. The circuit designed uses a MAX890L high-side current switch. The MAX890L allows the current limit to be set with an external resistor. When the current exceeds the limit, the device will cycle the power. The MAX890L is used to detect current increases greater than 200 milliamperes. Even though the PIC processor consumes less than 40 milliamperes during normal operations, the total dose radiation effects need to be considered. As the processor is exposed to radiation, the total dose accumulation will cause the processor to increase its power consumption over time. Total dose radiation testing showed that the processor consumed 180 milliamperes at its end of life. In the case that a small latchup occurs where the current increase is less than the limit, the voltage from the MAX471 current sensor is monitored for changes. It is possible for a latchup to occur in the processor and the processor to still operate. Software would be used to detect the smaller current changes. If the current change is determined to be a latchup, the processor can stop pinging the external watchdog timer. The watchdog timer is a MAX824. If it is not pinged within 1.6 seconds, it will cycle the power with a MOSFET transistor. If an SEU causes data or program execution to be corrupted, the processor will stop pinging the watchdog timer. All of these devices are connected in series. The MAX890L is connected to the power bus. Next, the MAX471 current sensor

is connected to the output of the MAX890L. The MOSFET transistor is connected to the output of the MAX471. The two Maxim parts can support up to 1 ampere of current. The power through each Maxim part is through a very low impedance resistor. The voltage drop is insignificant. The combination of hardware and software provide a robust latchup and SEU detection system.

The PIC controller underwent radiation testing at the Naval Research Laboratory. Exposing the die to a laser performed Latchup and SEU testing. The laser is used to approximate high energy particles. Latchup was determined to occur at about 17 MeV. When exposing certain parts of the die, the processor continued to operate during a latchup event. The maximum current measured during a latchup was 600 milliamperes. The PIC controller was never damaged by a latchup. The SEUs occurred at about 2 to 3 MeV. It took little energy to flip bits. Exposing the EEPROM to the laser actually induced program execution errors. None of the EEPROM bits could be flipped by laser exposure. The maximum energy level exposed was about 300 MeV. Even at this high energy level, no damage was induced. When the watchdog timer was exposed to the laser, it stopped working. It was not able to reboot the processor. An external watchdog timer is needed. For total dose testing, the PIC controller was exposed to an x-ray source. The x-ray source was calibrated so that it could be correlated to a cobalt-60 radiation source. The PIC controller failed after being exposed to 20 Krads. The failure was due to the EEPROM being set to all zeros. The PIC controller could be reprogrammed. For a second exposure, the PIC controller was exposed to an additional 15 Krads before complete failure. The PIC controller couldn't be reprogrammed after the second exposure.

The first payload will be a picosat attitude control experiment. The payload will control the spacecraft magnetorquers. It will have magnetic field sensors for each axis. The processor architecture will allow for software uploads. The processor will need to be fast enough to calculate orbital position from time and uploaded keplerian elements. At this time, one of the newer faster versions of the 80C52 eight bit processors has been selected. It can access external memory and peripherals. If the experiment is successful, then a more compact version of the 80C52 can be used. Radiation hardened versions of the 80C52 do exist for those who need longer duration missions. Subsequent satellite designs will incorporate the attitude control on the satellite controller.

Heidt

4.1.4 Satellite Structure Evolution

When the group started designing the CubeSat, the group went through a few design evolutions. The initial design specification early in the program was for a 3.5 inch cube. The design was highly modular. There are only two different types of panels. All of the side panels are identical. Each panel is made of 1/8-inch aluminum. The center area is machined out to allow for mounting of a solar panel and magnetorquer coil. The inner sides of the panels have rails machined to allow mounting of the circuit boards. The top and bottom panels are designed to deploy antennas. The antennas are constructed of piano wire and wrap around a racetrack machined into the top and bottom panel. A solar panel can be mounted on the panels. The panels also provide shielding for the RF electronics. The RF circuit board mounts to the panel. The components are oriented into the panel cavity. The circuit boards are stacked and can slide into a partially assembled structure using the rails on the side panels.

Assembly is simple. The RF circuit board has connectors for each face. The connectors are used to connect the solar cells, magnetorquers, and sensors to the bus. The side panels contain the mating connectors. The side panels are attached to the top and bottom. The connectors help in alignment and provide the snap together assembly. Assembling three sides to the top and bottom panels allows the circuit board stack with battery compartment to be slid into the structure. The last side panel is then snapped in and all screws can be inserted.

4.2 Dartmouth College

4.2.1 Introduction

DARTSat is a CubeSat being designed and built by students and faculty at the Thayer School of Engineering at Dartmouth College. This program is to take a modular approach to educational and research microsatellite design. Professor August S. Moore directs this program.

An initial structure design was based on the 3.5-inch cube. The main difference is increasing the size to a 10-centimeter cube and adding rub rails. The 10 cm cube meets the CubeSat structure requirements. The panels were designed for solid panels 1/8 inch thick. Then the problem with the design was that the mass

exceeded the limit. The structure had a mass greater than 1.5 kilograms.

The latest design uses minimal aluminum. Four slotted posts are connected together with thin sheets of aluminum. The assembly requires epoxy. No screws are used. The circuit boards contribute to the structural strength. The battery is not mounted in an enclosure. It is epoxied between two circuit boards.

4.2.2 Standardized Design

The Stanford / Calpoly CubeSat program has presented a unique opportunity to develop a modular architecture for extremely small educational and research spacecraft. The vision is to develop a standardized satellite bus that provides basic power, control, and communications functionality to one or two miniaturized payloads. These payloads are constructed as stand-alone components with standardized interfacing that will allow them to be “snap-in” additions to the DARTSat bus. Service modules are manufactured and subsequently paired with unique payloads as specific launch opportunities are realized.

The first generation DARTSat is a testbed for this concept and will begin an ongoing program of satellite development and space-based research at Dartmouth College’s Thayer School of Engineering.

4.2.3 CubeSat Design

The approximately 4-inch cube specified by the CubeSat program defines the overall configuration of DARTSat. Of the 61 cubic inches available in the configuration, 75% are dedicated to the satellite bus and structure. A payload bay, designed to accept either several PCBs or a component box measuring 3 by 3 by 1.5 inches, is situated on one side of the cube. Photovoltaic cells are installed on five of the six sides of DARTSat. The side not covered is optimized as a radiator to regulate the satellite’s internal thermal environment and act as the deployment point for the satellite’s four antennas. DARTSat is passively oriented to the earth’s magnetic field to provide consistent pointing of communications antennas, experiment sensors, and photovoltaic panels.

DARTSat’s highly integrated Microprocessor Control Unit (MCU) is extremely compact and occupies a single PCB that is only 2.75 inches square. It is designed around the Intel 8051 family of microcontrollers. The microcontroller’s firmware operating system performs all of the satellites major

Heidt

functions, including burst transmission of experimental data, power management, and mode switching for the satellite’s transmitter. Ground control of microprocessor functions is accomplished through simple strings of “touch-tones” interpreted by a Dial-Tone MultiFunction (DTMF) decoder. A 9800 bps packet modem is installed to transfer both research and satellite system data via groundstations equipped with standard HAM radio packet data receiving capability. And a simple Power Allocation and Monitoring (PAM) subsystem, commanded by the MCU, will provide real-time control of the power consumption of individual components and subsystems. Electrical power is distributed on a 3.6V bus. Two, 3.6V Li-Ion battery packs are used to provide redundancy and buffer the power generated by the external GaAs photovoltaic panels.

Satellite communications is accomplished through FM Amateur Radio Frequencies. Use of two frequencies, the 144 MHz band for transmitting and 440 MHz band for receiving, maintains flexibility, decreases transceiver complexity, and allows the satellite to be used as a HAM radio repeater. Deployable dipole antennas, one for each band, provide fairly efficient transmission strength and the passive pointing provided by the earth’s magnetic field insures good ground reception as the satellite passes over North America.

4.2.4 Conclusion

The DARTSat team has focused its efforts on the development of the satellite service bus. Payloads for DARTSat are under development here at Dartmouth and at other institutions. These include plasma and auroral mapping experiments and unique GPS applications. Because the extremely modular nature of DARTSat allows for payloads to be conceived and produced independently from the satellite services, a wide variety of payloads from a large number of sources are possible.

4.3 University of Tokyo

4.3.1 Introduction

Intelligent Space Systems Laboratory (ISSL), a laboratory directed by Prof. Nakasuka in the Department of Aeronautics and Astronautics, University of Tokyo, has been studying a large membrane space structure for several years with an intention to apply it to huge solar cells, communication antenna, debris catcher or other

missions⁷⁻⁹. One way to deploy such large membrane in space is to use centrifugal force. The mission of ISSL's CUBESAT is to experiment the deployment of large thin film solar cells using centrifugal force generated by spinning the satellite main body. Figure 4.3.1 shows the image of the satellite with its membrane deployed. The results of the experiments will be useful for studying the way of deploying a huge membrane as well as finding out a simple way to provide large power to small satellites without much complicated systems.

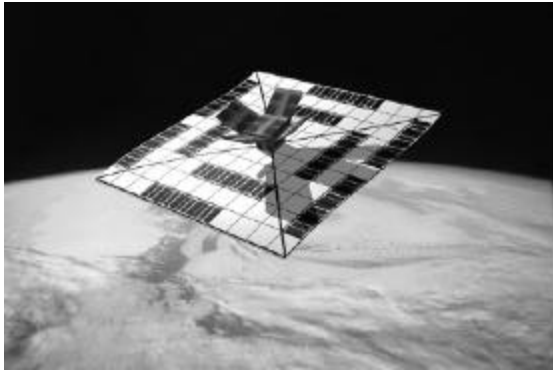

Figure.4.3.1 Image of Univ. of Tokyuo CUBESAT on orbit with Membrane Deployed

In the CUBESAT mission, we specified the following four success levels, which also show the mission scenario.

Level 1) Educational objectives to experience satellite design, fabrication, testing, launch, operation and analysis of results.

Level 2) To receive some beacons from the satellite. This success means that the satellite could endure the environment of launch, and that the subsystems needed for downlink communication work properly in space.

Level 3) Successful experiment of deployment of membrane and receive of the experiment data by using uplink command. All the operation until this level is performed using the power loaded on the battery before launch.

Level 4) The solar cell on the membrane supplies power to the battery and the satellite will survive for some period.

4.3.2 Brief Description of the Satellite and Subsystems

4.3.2.1 Weight and Power Budget

The design is under way and so some parts are subject to change.

4.3.2.2 Membrane

Figure 4.3.2 shows the configuration of the membrane. Total 120 solar cells are glued to some part of the Kapton membrane, which will produce 27.9 W when the solar angle is maximum. The size of the membrane after deployment is 880 mm by 880 mm, and it is before deployment folded around the cubic body of the satellite.

Several experiments to find out the required rotational speed to deploy the membrane successfully have been performed, which indicated that the rotational speed of 20 rpm is required to deploy the membrane from the folded position, and that 5 rpm is required to keep the shape of the membrane after deployment.

Figure 4.3.2 Configuration of Membrane (after

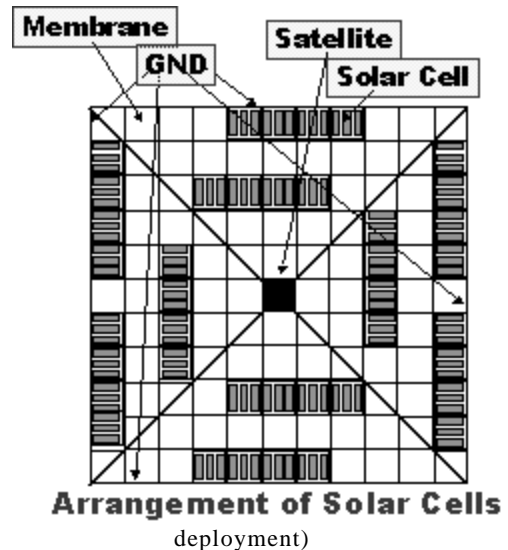

4.3.3 Schedule

Figure 4.3.3 shows the current schedule.

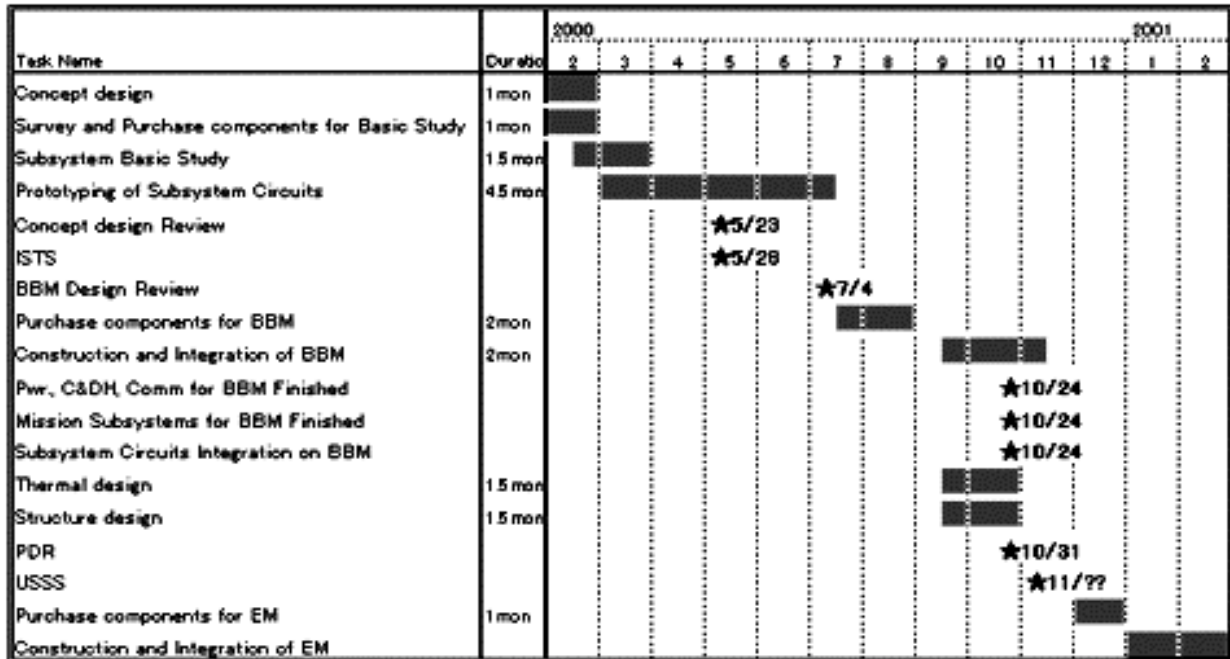

Figure 4.3.3 Schedule of University of Tokyo
CubeSat

4.4 California Polytechnic Institute

4.4.1 Introductions

One of the main objectives of the CubeSat program is the development of a new class of standardized picosatellites. The CubeSats' size and mass standards, 100 mm cube and 1 kg respectively, are developed as an extension of the picosatellites deployed by Stanford's OPAL spacecraft. The CubeSats' dimensions are large enough to provide significant power through the use of body mounted solar cells. Moreover, the CubeSats' mass is large enough to carry a significant payload given current developments in small and efficient sensors, processors and communications equipment.

Beyond the initial form factor and mass of the CubeSats, additional standard features are determined by the need to interface the spacecraft with a standard deployment system. The CubeSat deployer must satisfy a number of requirements:

- The deployer must protect the launch vehicle and primary payload from any mechanical, electrical or electromagnetic interference from the CubeSats even in the event of a catastrophic CubeSat failure.
- The CubeSats must be released from the deployer with minimum spin and a low probability of collision with the launch vehicle or other CubeSats.
- The deployer must have the ability to interface with a variety of launch vehicles with minimum modifications and with no changes to the CubeSat standard.
- The mass of the deployer should be kept to a minimum.
- The deployer should incorporate a modular design that allows different numbers of CubeSats to be launched on any given mission.
- The resulting CubeSat standard should be easily manufactured without using exotic materials and expensive construction techniques

The Poly Picosatellite Orbital Deployer (P-POD) shown in Figure 4.4.1 is the result of a lengthy development process by Cal Poly students to satisfy the requirements above. The tube design produces a reliable linear course for the CubeSats without significant spin. This deployment method was successfully demonstrated in the Opal mission. The tube provides an enclosure strong enough to handle the structural failure of one of the CubeSats while providing a Faraday cage to protect the primary payload. During the deployment sequence the CubeSats ride on rails built into the corners of the tube (see Figure 4.4.1) and a simple spring provides

Heidt

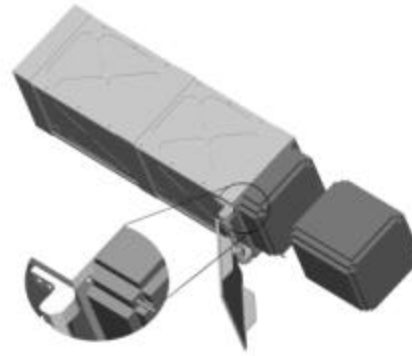

Figure 4.4.1: P-POD releasing CubeSats with rail detail.

the force to push the CubeSats out of the deployer with a linear velocity of approximately 0.3m/s. Deployment is initiated by the release of the P-POD's spring loaded door using a G & H Technologies cable release actuator. The standard P-POD deployer contains 3 CubeSats although the design could be lengthened to fit a larger number of CubeSats. In addition, the P-POD's design allows a number of deployers to be mounted together on a launch vehicle as shown in Figure 4.4.2. The P-POD is constructed using 7075-T6 Aluminum due to this material's high strength, ease of manufacture and relative low cost. The deployer is designed to sustain 15g loads resulting in a total P-POD mass of approximately 1.5 kg.

Given the P-POD's design, a final set of standards for the CubeSats can be developed. A CubeSat specification drawing is shown in Figure 4.4.3. In addition to the basic size and mass requirements some standard requirements are introduced by the deployer.

- * The CubeSat needs 8.5 mm clearance on the four side edges, which will be used to slide along the internal rails of the deployer (Figure 4.4.1).
- * Eight 7 mm standoffs on the top and bottom faces of the CubeSat are required to provide separation between CubeSats.
- * On top of each side, excluding space for the rails and standoffs, an additional 6.5 mm space is available to accommodate solar panels, antennas, or other components extending beyond the 100mm limit.
- * A minimum of one kill switch is required in the standoffs on the top plate (Figure 4.4.3) to insure that none of the CubeSats are active during launch. Along with the kill switches there is also a requirement for a "remove before flight" pin, to deactivate the CubeSat during shipping and loading.

An optional data port can be included in the design in order to complete last minute check or to charge internal batteries after the CubeSat is loaded into the deployer.

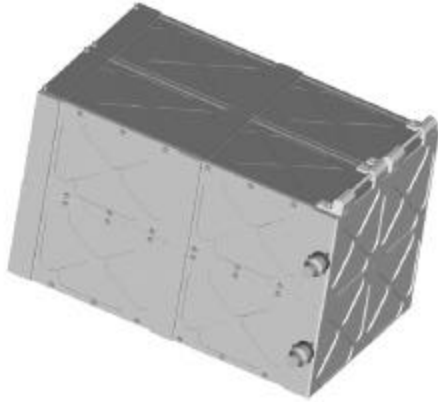

Figure 4.4.2 Four P-POD's in a 2x2 configuration

4.4.2 PolySat: Cal Ploy's Prototype CubeSat

The Cal Poly prototype CubeSat, PolySat, meets the deployer's constraints for size, mass, shape, and interface. The purpose of our prototype is twofold: first, to validate the deployer standard design and second, to demonstrate that CubeSats provide a viable platform for basic experiments in a space

environment. PolySat is a minimum configuration satellite, consisting of a simple set of components required to demonstrate low-Earth orbit operation.

PolySat's structure is consistent with the deployer's standard. A 100 mm cube has been designed with the required guide rails and interface for the deployer. The structure is composed of six individual panels of aluminum 7075-T6, totaling a mass of 0.2 kg and strong enough to survive launch loads. Mount points for antennas on the exterior and various internal components are provided.

The communications system consists of a downlink transmitter, an uplink receiver, and independent antennas for each. Downlink is provided by a modified on-board Alinco DJ-C4T 440 MHz amateur radio transmitter. This is commercially available for \$70 retail, and offers 300 mW output, at a cost of 1.11 W when transmitting. It is very robust and compact. Further, it generates very little heat in operation and has low idling power requirements. Both our own requirements and FCC amateur regulations demand an independent uplink receiver capable of providing a minimum of an "off" command for the downlink transmitter. Requirements analysis revealed that commonly available amateur radio receiving equipment would likely suffer from overload and serious intermodulation distortion (IMD) from strong earth generated signals on nearby frequencies was solved by using a MICRF004.

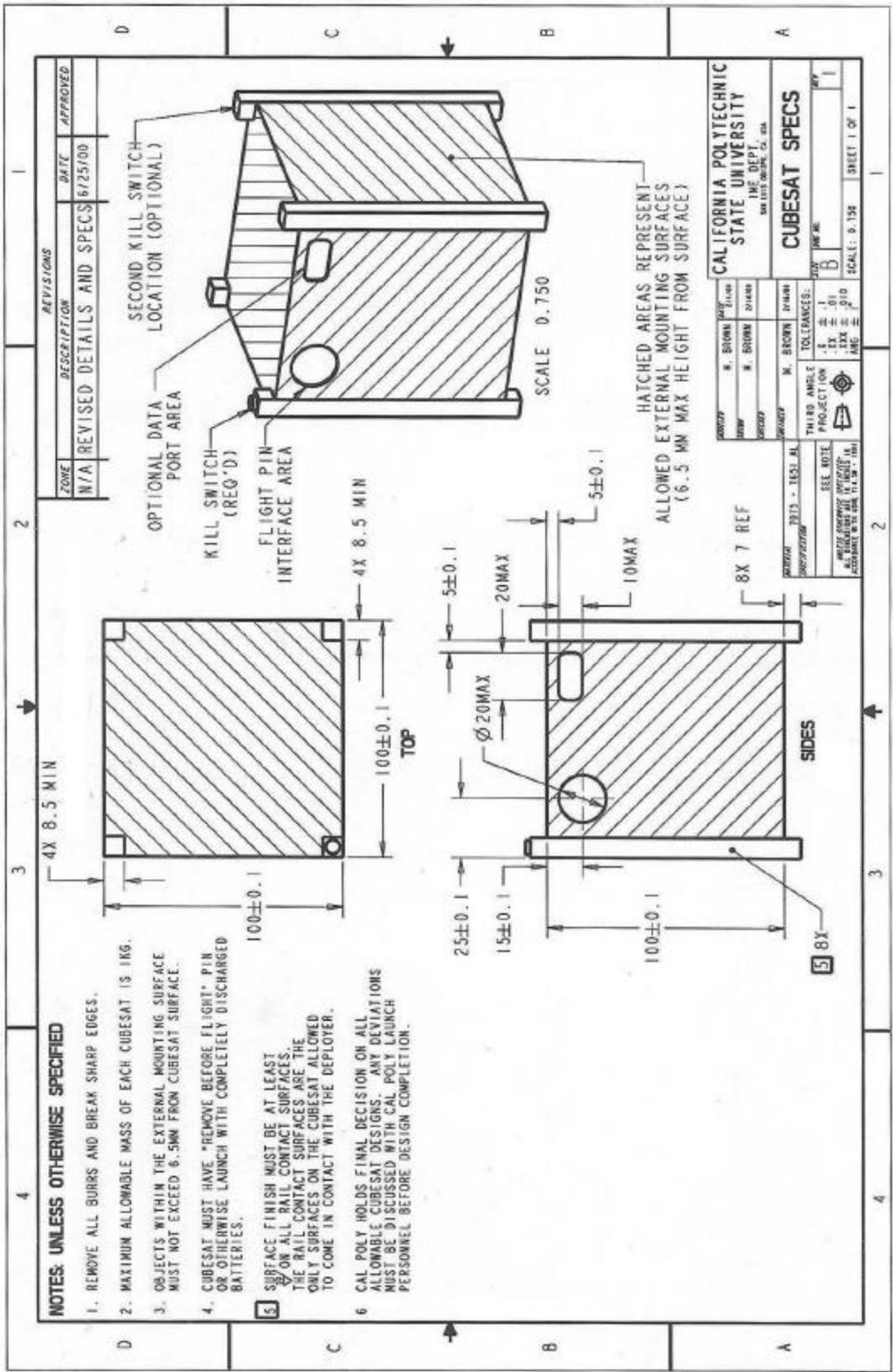

Figure 4.4.3 CubeSat specification drawing

This data receiver on a chip (commonly used for garage door opener receivers) is from Micrel, Inc. This solution is quite cheap to implement at about \$30. It is easily modified to receive in the 144 MHz amateur radio band with extremely low power requirements and low sensitivity. Low sensitivity, usually a disadvantage, affords the CubeSat uplink receiver relative immunity to spurious signals. Compensation is easily provided on earth by increased amplification and antenna gain with commonly available amateur radio components. This receiver choice enables future enhancements for the uplink channel such as reset command or even simple reprogramming of the onboard processor.

Independent dipole antennas mounted on one face of the box provide the downlink and uplink capability. The antenna design mirrors the technique used on OPAL, namely metal "measuring tape" available at any hardware store. It is flexible, holds its shape well and has served as adequate material on previous missions. The antennas are folded down against the satellite body with monofilament held down by a short length of nichrome wire. Upon deployment, a current is passed through the nichrome wire, which will heat the monofilament and release the antennas.

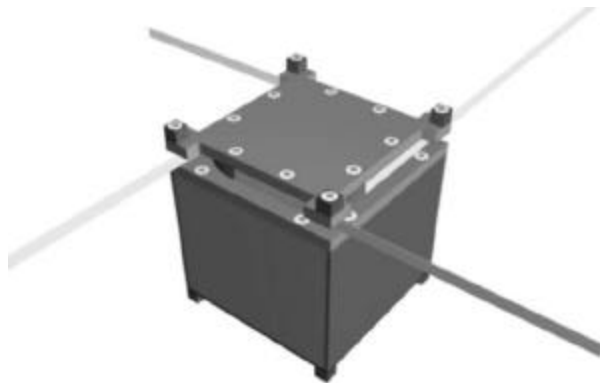

Figure 4.4.4. The PolySat with Deployed Dipole Antennas

Amateur radio frequencies (and licenses) are used for low cost and a readily accessed base of experience. In addition to inexpensive, commonly available equipment, there exists a large network of amateur radio operators with well-equipped ground stations available to assist in our mission. This is a tremendous advantage for a small startup group of undergraduate students.

Command is provided by an Atmel BasicX PIC microcontroller running custom software, written for the project. This chip provides 8 digital and 8 analog lines for I/O. The processor activates the transmitter at required intervals for downlink tasks. The FCC required identification of the transmitter is given in Morse code using tone modulated FM under the call sign "N6CP" (Cal Poly's Amateur Radio Club) followed by mission specific data. The data is encoded using dual tone multi frequency (DTMF) tones by the processor. The transmitter is keyed by the processor at specified intervals while the encoded data is passed to the audio input for transmission. The use of DTMF encoding involves a relatively slow rate of data transfer but increases the simplicity and reliability of our link. This can be important if we unexpectedly lose gain or experience increased noise on the frequency. Currently, sensors being considered for PolySat include thermistors to measure the temperature of the structure and key components as well as a voltage sensor for the batteries.

Power is provided by two on-board battery packs consisting of two lithium-ion batteries each. Step-down converters are used to provide 5V to the computer and receiver and 3.7V for the transmitter. This battery pack provides 209 watt-hours using four cells of 116g each. This represents approximately 150 hours of transmitting time.

PolySat uses passive thermal control, using coatings and paints to control heat radiation and absorption. Operating range is expected to be -40°C to 70°C.

As described, the PolySat spacecraft is well under the 1kg mass constraint. Since the transmitter operates only for small periods of time at specified intervals, it is expected to maintain operation over a lifespan of several weeks.



Figure 4.4.5 Disassembled CubeSat Showing Batteries and Electronics Tray

4.4.3 Future Advances

The main objective of the initial CubeSat mission will be to validate the design of the standardized deployer. Once the deployer is space qualified it will become a new option to place small payloads in space with low development time and cost. In addition, initial CubeSat missions will validate the PolySat design and will qualify a number of components that the Cal Poly team plans to use in future CubeSats. In particular, the Cal Poly team is interested in validating the spacecraft structure, the antenna deployment system, the communications package and the spacecraft thermal models. Space qualification of these components will facilitate the development of more sophisticated CubeSats in the future.

The Cal Poly team is currently working on the development of a solar powered CubeSat. Using the latest solar cell technology, body-mounted solar panels should provide around 1 W of continuous power to the spacecraft. A solar powered CubeSat would require a much smaller battery and an additional 0.2 to 0.25 kg of payload could be incorporated. New components that are currently being considered are a more powerful computer with more storage capacity, a small CCD camera and a small magnet to provide some attitude control capabilities, in addition the Cal Poly team is seeking commercial payloads to be flown in future CubeSat missions.

4.4.4 Acknowledgements

Bob Twiggs at Stanford University SSDL provided advice, knowledge, guidance, and funding in the development of Cal Poly's CubeSat program. Ed English (W6WYQ) and Cliff Buttschardt (K7RR), local amateur radio operators affiliated with AMSAT, provided technical assistance and materials. TRW, Inc, provided much needed funding for the project. G&H Technologies provided much needed hardware for the project. Palm, Inc. generously provided free hardware. Alinco Electronics provided technical assistance and products. CAD Research Center, Cal Poly, provided support for student projects.

5. LAUNCH OPPORTUNITIES AND COSTS

The launcher tube, PPOD, being developed by Cal Poly to hold three CubeSats is designed to be attached to many different launch vehicles. The PPOD launcher will be rectangular tube about 4.5 inches square by 15 inches long and weigh about 5 kg. It would require only a small power activation signal from the last stage of the launch vehicle to activate the release mechanism and open the launcher door to release the CubeSats. Since the launcher completely contains the picosatellites, can be attached in a very small space and is lightweight, many launch vehicles can accommodate this secondary payload. Multiple P-PODs could be attached to one launch vehicle for secondary payloads.

There are several flight opportunities for CubeSats in the near future. Two launch opportunities are now available from with Thiokol Corporation in a joint Venture with Kosmotras on the converted Russian SS-18 called the Dnepr from the Russian launch site at Baikonour. The first flight is scheduled for March 2001 with a second one in late 2001. These opportunities are being coordinated through One Stop Satellite Services in Ogden, Utah. It is expected that these flights will continue to occur at least twice a year.

The Aerospace Corporation, which was a partner on the OPAL projected and provided picosats for launch on that mission, is continuing picosat development with launches on the OSP-II (second Minotaur) from Vandenberg AFB, CA in 2001. Additional US launch opportunities are quite likely on many Boeing and Lockheed Martin launch vehicles.

The Air Force OSP-III (third Minotaur) is now scheduled for launch in late 2002 in which as many as 15 CubeSats are proposed to be launched from it.

5.1 Launch Costs and Procedure

The estimated launch cost per CubeSat that weights one kilogram or less is \$30,000. This is based on the known launch and integration cost using the Kosmotras Dnepr. The present arrangements being made for launches on the Dnepr is a collaborative effort between Stanford University, Cal Poly and One Stop Satellite Services in Ogden, Utah. Contractual arrangements will be made with Stanford University; Cal Poly will provide P-POD test fixture to the customer, provide the flight P-POD, integrate the CubeSat into the P-POD upon delivery to Cal Poly at San Luis Obispo, CA, perform final thermal and vacuum testing; then the P-POD will be shipped to One Stop Satellite Services at Ogden, Utah. One Stop Satellite Services will then be responsible for all export licensing, shipping to Kosmotras and integration onto the Dnepr.

6. CONCLUSIONS

The OPAL program demonstrated that a low cost launch system could be used to launch picosatellites. The success of The Aerospace Corporation picosatellites demonstrated the first use of these picosatellites. The new picosatellite, CubeSat, now proposed as a standard that can be launched with the launcher tube developed by Cal Poly, the P-POD will provide low cost opportunities for a new era in space experimentation.

These new CubeSats and the low cost make it practical for even universities and private groups such as amateur radio clubs to have access to space. The future of these space devices based on the CubeSat design will now depend upon how innovative the science and general community can be.

7. ACKNOWLEDGEMENTS

The initiation of the mother/daughter picosatellite work started at Stanford was done through the work of Professor Tom Kenny in the Stanford mechanical engineering department and Mr. Jim Randolph at the Jet Propulsion Laboratory. The final push to meet OPAL's mission was due to Ernie Robinson at The

Aerospace Corporation and Al Pisano, the director of the MEMS activity at DARPA.

Many students at Stanford worked very long and hard at completing SAPPHIRE, which was the predecessor to OPAL, and OPAL. Foremost of these students supporting SAPPHIRE over several years were Mike Swartwout and Chris Kitts. The OPAL effort was led initially by Brian Engberg, Clem Tillier and Carlos Niederstrasser and finally by Jamie Cutler and Greg Hutchins. These two projects had more than one hundred students work on them over a five year period. SSDL has outstanding mentors group to support students in their work with much volunteer effort from John Ellis, Lars Karlsson, Dick Kors, Ron Ross, Richard Anderson and David Joseph to name a few.

Boeing, DARPA, NASA Ames Research Center, NASA Langley and Jet Propulsion Laboratory provided research support for SSDL. Lockheed Martin, Space Systems/Loral, Deskin Research and The Aerospace Corporation provided additional financial and facilities support.

The CubeSat program as done in collaboration with Prof. Jordi Puig-Suari at Cal Poly demonstrates the motivation that a space program can bring to education. The Cal Poly students like Ryan Connelly and Jeremy Schoos are examples of students excited, enthusiastic and motivated by their education. These students are the most valuable output of these programs.

8. REFERENCES

- 1 "Initial Developments in the Stanford SQUIRT Program", Christopher A. Kitts and Robert J. Twiggs, EUROPTO, European Symposium on Satellite Remote Sensing, Rome, Italy, September 26-30, 1994.
- 2 "The Satellite Quick Research Testbed (SQUIRT) Program", Christopher A. Kitts and Robert J. Twiggs, 8th Annual AIAA/USU Conference on Small Satellites, Logan Utah, August 29 - September 1, 1994.
- 3 "Initial Developments in the Stanford SQUIRT Program", Christopher A. Kitts and Robert J. Twiggs, EUROPTO, European Symposium on Satellite Remote Sensing, Rome, Italy, September 26-30, 1994.

- 4 "The Satellite Quick Research Testbed (SQUIRT) Program", Christopher A. Kitts and Robert J. Twiggs, 8th Annual AIAA/USU Conference on Small Satellites, Logan Utah, August 29 - September 1, 1994.
- 5 "SAPPHIRE, A University Student Built Satellite for Space Experimentation", Twiggs, Robert J., and Christopher A. Kitts, November 1, 1995, The AMSAT Journal, November/December 1995.
- 6 "Picosat Free Flying Magnetometer Experiment", Clarke, D.S., M.T. Hicks, A.M. Fitzgerald, J.J. Suchman, R. Twiggs, T.W. Kenny, and J. Randolph, June 15, 1996, Proceedings of the Tenth Annual AIAA/USU Small Satellite Conference, September 16-19, 1996. Presented by Michael T. Hicks at the Tenth Annual AIAA/USU Small Satellite Conference, New Missions I Session, Logan, UT, September 16, 1996
- 7 Motohashi, S., Nakasuka, S., Aoki, T., Narusawa, Y., Nagashima, R., Kawakatsu, Y. and Kinoshita, T., On-orbit Dynamics and New Control Scheme for Large Membrane "Furoshiki" Satellite. Proceedings of 21st ISTS, 98-e-20, 1998
- 8 Narusawa, Y., Aoki, T., Nakasuka, S., Motohashi, S., Nagashima, R., Kawakatsu, Y. and Kinoshita, T., Behavior of Membrane Structure under Microgravity Environment, Proceedings of 21st ISTS, 98-b-16, 1998
- 9 Motohashi, S., Nakasuka, S., On-orbit Dynamics and Control of Large Scaled Membrane with Satellites at its Corners, Proceedings of IFAC Symposium on Aerospace Control, pp. 146-151, 1998